



BLASTECHNIK

TDF DUST COLLECTOR

Lowest Cost Per Square Meter Blasted.
Environmentally Friendly Non-polluting Facility.
Operator Friendly and Safe Working Environment.
High Quality Surface Preparation and Finishing.

EXCELLENT BLASTING VISIBILITY AND NO POLLUTION TO MEET TODAY'S STRICT ENVIRONMENT AND SAFETY REQUIREMENTS.

Forget poor blasting visibility, dusty surrounding working areas and environmental pollution. Blasttechnik TDF Ventilation Dust Collectors will totally eliminate these problems commonly found with poorly designed blastrooms.

Unlike conventional cartridge type dust collectors, in which the dust, pulsed from the filters, is falling downwards into an incoming upflow air stream, the TDF design is the total opposite. The TDF incoming air flow is from the top of the dust collector and the filter cartridges are pulsed clean in the same direction as the airflow, directly into the outlet collection hopper. This unique feature greatly increases the filter cleaning efficiency and prevents the filter cartridges becoming clogged with dust. This results in the dust collector providing constant performance and greatly extends the life of the filter cartridges.

The high efficiency performance, and high velocity ventilation air flow, of the Blasttechnik TDF Ventilation Dust Collector ensures excellent visibility in the blastroom and prevents any dust escaping to the environment or surrounding working areas.

To reduce operators noise exposure the reverse pulsing valves are positioned inside the dust collector as opposed to mounted externally. All noise is then contained within the dust collector.

Knock down bolt together design ensures quick and easy on site erection to reduce assembly time to a minimum.

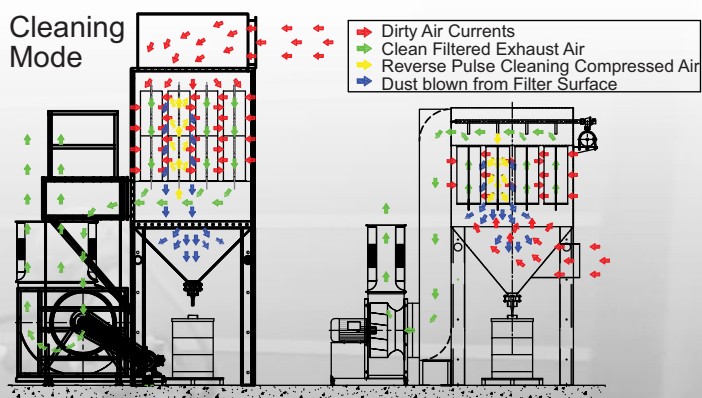
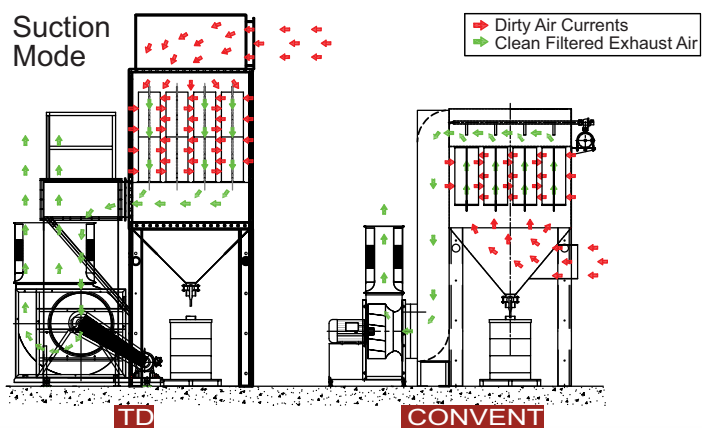

Standard items supplied with TDF dust collector - magnetic differential pressure gauge, compressed air regulator, maintenance access platform (24 cart and above), exhaust fan starter, exhaust fan silencer.

Optional items - screw conveyor and rotary airlock discharge, explosion vent, discharge airflow dampener, exhaust ducting, variety of filtering media, dirty air inlet maybe located either side.

TDF dust collectors up to 16 cartridges are fitted with direct mounted fan. TDF dust collectors 24 cartridges and above are fitted with floor mounted fan.

Dimensions and illustrations are indicative only and subject to change depending on final dust collector design and configuration.

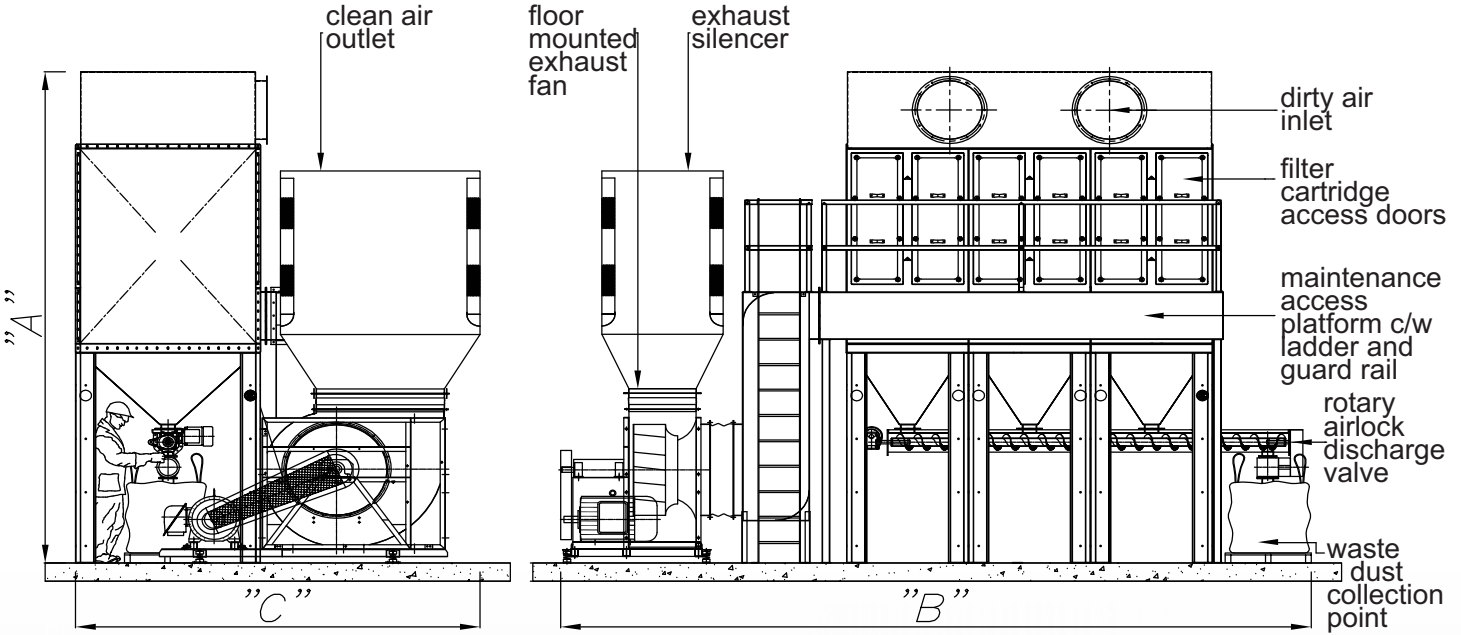
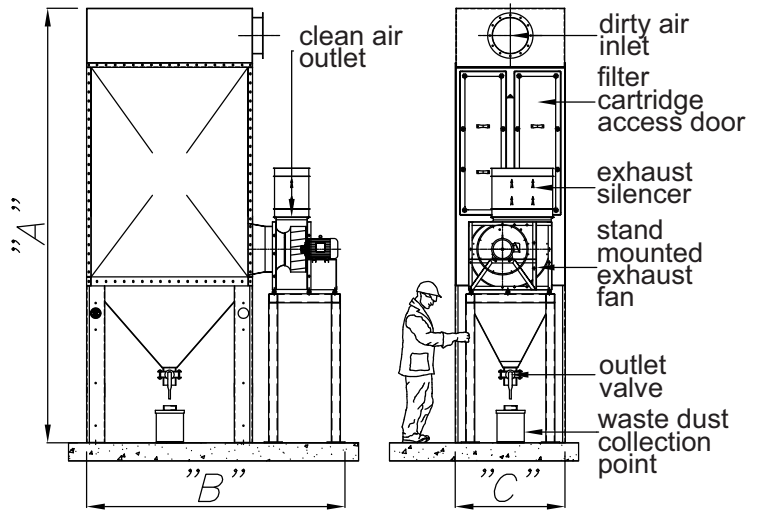

TDF Dust Collector Dimension

TDF Model	DIM A	DIM B	DIM C	A (M ²)	Q (M ³ /HR)	KW
TDF 2 DC	1,750	1,508	606	54	2,107	3.75
TDF 4 DC	3,310	2,000	1,206	84	3,580	5.5
TDF 6 DC	3,310	2,430	1,206	126	5,196	5.5
TDF 8 DC	3,745	2,000	1,206	168	7,767	11
TDF 12 DC	4,200	2,430	1,206	252	10,224	11
TDF 16 DC	4,790	2,800	1,206	336	14,742	18.5
TDF 24 DC	4,850	4,030	2,655	504	20,390	30

TDF Model	DIM A	DIM B	DIM C	A (M ²)	Q (M ³ /HR)	KW
TDF 32 DC	5,450	4,505	3,150	672	27,184	37
TDF 48 DC	5,625	5,980	3,450	1,008	40,776	55
TDF 60 DC	4,985	8,280	3,260	1,260	50,970	75
TDF 64 DC	5,590	7,600	3,630	1,344	54,368	75
TDF 80 DC	5,570	9,135	3,790	1,680	67,960	90
TDF 96 DC	5,630	10,860	4,010	2,016	81,552	110
TDF 112 DC	5,680	12,585	4,245	2,352	95,144	110

All dimensions are in millimeters.



TDF dust collector installed around the world.

TDF DUST COLLECTOR

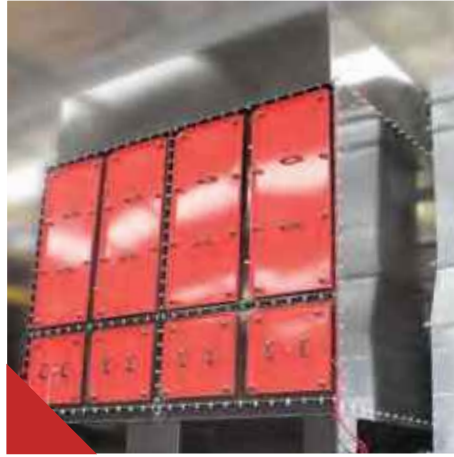

 **Blasttechnik**
Blastrooms

www.painttechnik.com

© 2013 - 2022 Blasttechnik Pte Ltd

Blasttechnik Pte Ltd
11 Tuas South Link 1, #03-18
SHINE@TUAS SOUTH
Singapore - 636901
Tel. +65 6505 9098 | H/P. +65 98500121
sales@blasttechnik.com